

REGIONAL DISTRICT OF NANAIMO

BYLAW NO. 500

SCHEDULE '3A'

ZONING MAPS

REGIONAL DISTRICT OF NANAIMO

BYLAW NO. 500

SCHEDULE '3B'

OFF-STREET PARKING & LOADING SPACES

1. GENERAL REQUIREMENTS

1.1 Location

All off-street parking and loading spaces shall be located:

- a) on the same parcel as the development, building or use they are intended to serve;
- b) subject to the setback requirements of the zone that applies to that parcel.

1.2 Disability Spaces

- 1) When any development, building or use requires or provides more than 20 off-street parking spaces, one parking space shall be provided for the use of persons with a physical disability, together with one additional disability space for each additional 50 off-street parking spaces required or provided.
- 2) Each disability space shall be:
 - a) a minimum of 4.0 m in width;
 - b) marked with the International Symbol of Accessibility for the Handicapped as specified in Table 3 of this Schedule; and
 - c) located within convenient access of the development, building or use that it is intended to serve, and with minimum changes in level.

1.3 Surface

When any development, building or use requires or provides more than 4 off-street parking spaces, all parking spaces and loading spaces shall be provided and maintained with a hard durable surface that does not produce dust.

1.4 Gradient

All parking and loading spaces shall have a maximum gradient and cross-slope of 6%.

2. OFF-STREET PARKING SPACES

2.1 Stall and Aisle Dimensions

All off-street parking spaces shall be in accordance with Table 2 of this Schedule.

2.2 Reduction in Stall Length for Small Cars

When any development, building or use provides more than 100 parking stalls, up to 20% of the total stalls may be reduced to 4.6 m in length provided those stalls are combined in groups of at least 20 stalls, and marked with the words "SMALL CAR ONLY" on the pavement or wall facing.

2.3 Access

Adequate provision shall be made for access by vehicles to all off-street parking spaces located in a parking area by means of unobstructed maneuvering aisles, the dimensions of which shall be in conformity with Table 2 of this Schedule.

2.4 Vertical Clearance

The minimum vertical clearance of parking stalls and aisles shall be 2.25 m.

2.5 Calculation

- 1) The minimum number of off-street parking spaces shall be provided in accordance with Table 1 of this Schedule.
- 2) If a use is not listed in Table 1, the number of spaces shall be calculated on the basis of a similar use that is listed.
- 3) If more than one use is located on a parcel or parking collectively serves more than one building or use, the total number of spaces shall be the sum of the various classes of uses calculated separately, and the parking or loading space required for one use shall not be included in calculations for any other use.
- 4) Where the calculation of a total required space results in a fractional number, the nearest whole number above that calculation shall be taken.
- 5) The required number of off-street parking spaces need not be provided where an addition or alteration to a building or a change in its use would result in an increase of less than 10% of the number of spaces required up to a maximum of 5 spaces; where an addition, alteration or change in use requires more than 5 spaces the number of spaces determined by Table 1 shall be provided.

3. LOADING SPACES

3.1 Dimensions

All off-street loading spaces shall be a minimum of 9.0 m in length and 3.0 m in width, and have a vertical clearance of 4.0 m.

3.2 Access

Adequate provision shall be made for access by vehicles to all off-street loading spaces by means of a 6.0 m maneuvering aisle and shall be located so that each separate use within a development has access to a space.

3.3 Demarcation

All off-street loading spaces shall be clearly marked with the words "LOADING SPACE ONLY" on the pavement or wall facing.

3.4 Calculation

For commercial, industrial or public use 1 off-street loading space shall be provided for every 2000 m² of floor area or portion thereof of all buildings located on a parcel, except where a use requires less than 4 parking spaces then no loading space shall be required.

REGIONAL DISTRICT OF NANAIMO

BYLAW NO. 500

SCHEDULE '3B'

TABLE 1

REQUIRED NUMBER OF OFF STREET PARKING SPACES

The minimum number of off-street parking spaces shall be provided in accordance with the following table:

Use	Required Parking Spaces
Residential	
Mobile Home Parks	(see Schedule '3D' of this Bylaw)
Multi-unit dwellings	1 per 4 units (visitor) plus
- bachelor	1 per dwelling unit
- 1 bedroom	1.25 per dwelling unit
- 2 bedrooms	1.50 per dwelling unit
- 3 or more bedrooms	2 per dwelling unit
Single dwelling unit and duplex	2 per dwelling unit
Home based business, excluding bed and breakfast	2 plus 1 per non-resident employee
Bed and breakfast	1 per bedroom used for bed and breakfast
Commercial	
Agri-tourism Accommodation Cabin ¹	one per cabin
Animal Care	1 per 20.0 m ² of floor area
Automotive Repair ²	1 per 70.0 m ² gross floor area plus 1 per service bay
Bowling Alley	3 per lane
Campground	(see Schedule '3C' of this Bylaw)
Fairground	1 per 2 employees plus 1 per 100 m ² of site area
Fast Food Outlet	1 per 10.0 m ² of floor area
Farm Retail Sales ³⁺	one per 5 m ² of floor area plus one per two Employees
Financial Institution	1 per 20.0 m ² of floor area
Funeral Parlour	1 per 4 seats in Chapel
Gasoline Service Station	4 per service bay plus 1 per 15.0 m ² of floor area
Gathering for Events	1 spot per 4 guests must be available on the farm, but must not be permanent nor interfere with the farm's agricultural productivity and must be setback 15.0 m from all lot lines. ⁴
Golf Course (9 holes)	75 spaces per 9 holes

¹ Bylaw 500.383, adopted June 25, 2013

² Bylaw 500.408, adopted August 22, 2017

³ Bylaw 500.383, adopted June 25, 2013

⁴ Bylaw No. 500.413, adopted May 22, 2018

Golf Driving Range	2 per tee
Health Club, Spa, Games Court, Gymnasium	1 per 10.0 m ² of fitness or gymnasium floor area
Heavy Equipment Display	1 per 70.0 m ² of floor area
Hotel or Resort Condominium	1 per unit, plus 1 per 3 seats in restaurant or licensed premises, plus 1 per 4 units (visitor)
Laundromat	1 per 3 washing machines
Laundry and Dry Cleaning Establishment	1 per 2 employees counted as a total of 2 shifts
Marina	1 per 2 mooring berths plus 1 per 2 employees
Neighbourhood Pub	1 per 3 seats
Nursery	1 per 15.0 m ² of sales building
Office	1 per 15.0 m ² of floor area
- medical	
- single tenant	1 per 32.0 m ² of floor area
- multi tenant	1 per 30.0 m ² of floor area
Personal Service	1 per 50.0 m ² of floor area
Produce Market or Stand	1 per 5.0 m ² of floor area plus 1 per 2 employees
Restaurant	1 per 10.0 m ² of floor area
Retail, Tourist or Convenience Store	1 per 15.0 m ² of floor area
Shopping Centre- to 5000 m ² g.l.a.	6.5 per 100 m ² g.l.a.
- to 15 000 m ² g.l.a.	5.5 per 100 m ² g.l.a.
- above 15 000 m ² g.l.a.	1.5 per 100 m ² g.l.a.
Ski Resort	0.5 per person hourly capacity of ski lift
Theatre, Drive-in	1 per 2 employees
Industrial	
Medium Industry	1 per 50.0 m ² of floor area
Taxi Stand	1 per taxi plus 1 per office employee
Transportation Terminal (excluding Taxi Stand)	1 per 10.0 m ² of waiting room
All other Industrial Uses	1 per 175.0 m ² of floor area used for storage 1 per 95.0 m ² of floor area used for display 1 per 15.0 m ² of floor area used for sales
Public and Institutional Uses	
Beach, Swimming	1 per 9.0 m ² developed beach above high water mark
Cabin	2 per cabin
Church	1 per 4 seats
Church Hall, Lodge Hall, Private Clubs, Community Hall	1 per 20.0 m ² of floor area
College	10 per classroom
Day Care Facility	2 per facility plus 1 per employee
Hospital	1 per 2 employees plus 1 per 5 beds
Personal Care	1 per 3 beds
Police Office, Fire Station, Prison	1 per 2 employees counted as a total of 2 shifts
Recreational or Cultural Facility	1 per 50.0 m ² of floor area or 1 per 3 spectator seats or 1 per 5.0 m ² of floor area used for dancing or assembly or 1 per 4 persons capacity, whichever is the greater

Swimming Pool	1 per 5.0 m ² of pool water surface
Public Utility	1 per employee
School - Elementary	2 per classroom
- Secondary	5 per classroom
Tourist Information Booth	4 per employee

REGIONAL DISTRICT OF NANAIMO

BYLAW NO. 500

SCHEDULE '3B'

TABLE 2

PARKING STALL AND AISLE DIMENSIONS

The minimum parking stall and aisle dimensions shall be in accordance with the following:

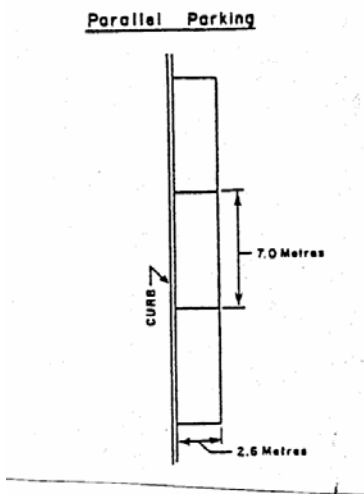
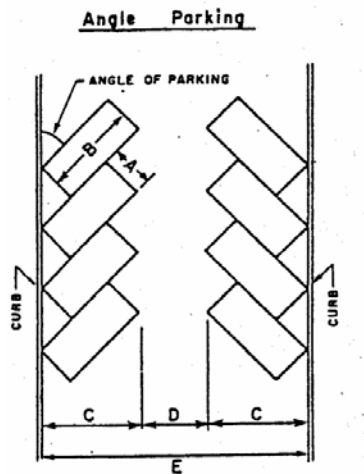

Angle	Stall Width (A)	Stall Length (B)	Stall Depth to Curb (C)	Aisle Width (D)	Module (E)
10 degrees	2.5 m	5.2 m	2.5 m	3.7 m	8.7 m
	2.6	5.2	2.6	3.7	8.9
	2.7	5.2	2.7	3.7	9.1
	2.8	5.2	2.8	3.7	9.3
	2.9	5.2	2.9	3.7	9.5
	3.0	5.2	3.0	3.7	9.7
20 degrees	2.5 m	5.2 m	4.3 m	3.4 m	12.1 m
	2.6	5.2	4.4	3.4	12.3
	2.7	5.2	4.5	3.4	12.4
	2.8	5.2	4.6	3.4	12.6
	2.9	5.2	4.7	3.4	12.8
	3.0	5.2	4.8	3.4	13.0
30 degrees	2.5 m	5.2 m	5.1 m	3.4 m	13.5 m
	2.6	5.2	5.2	3.4	13.7
	2.7	5.2	5.2	3.4	13.9
	2.8	5.2	5.3	3.4	14.0
	2.9	5.2	5.4	3.4	14.2
	3.0	5.2	5.5	3.4	14.4
40 degrees	2.5 m	5.2 m	5.6 m	3.9 m	15.2 m
	2.6	5.2	5.7	3.7	15.1
	2.7	5.2	5.8	3.7	15.3
	2.8	5.2	5.9	3.7	15.4
	2.9	5.2	5.9	3.7	15.6
	3.0	5.2	6.0	3.7	15.8
45 degrees	2.5 m	5.2 m	5.9 m	4.3 m	16.0 m
	2.6	5.2	5.9	4.1	16.0
	2.7	5.2	6.0	3.9	15.9
	2.8	5.2	6.1	3.9	16.1
	2.9	5.2	6.2	3.9	16.2
	3.0	5.2	6.2	3.9	16.3
50 degrees	2.5 m	5.2 m	6.1 m	4.3 m	16.4 m
	2.6	5.2	6.1	3.8	16.0
	2.7	5.2	6.2	3.7	16.1
	2.8	5.2	6.2	3.7	16.2
	2.9	5.2	6.3	3.7	16.3
	3.0	5.2	6.4	3.7	16.4
60 degrees	2.5 m	5.2 m	6.3 m	5.8 m	18.3 m
	2.6	5.2	6.3	5.6	18.2
	2.7	5.2	6.4	5.5	18.2
	2.8	5.2	6.4	5.5	18.3
	2.9	5.2	6.5	5.5	18.4
	3.0	5.2	6.5	5.5	18.5
70 degrees	2.5 m	5.2 m	6.3 m	5.8 m	18.3 m
	2.6	5.2	6.3	5.6	18.2

Aisle	Stall Width (A)	Stall Length (B)	Stall Depth to Curb (C)	Aisle Width (D)	Module (E)
	2.7	5.2	6.4	5.5	18.2
	2.8	5.2	6.4	5.5	18.3
	2.9	5.2	6.4	5.5	18.4
	3.0	5.2	6.5	5.5	18.5
80 degrees	2.5 m	5.2 m	6.1 m	7.6 m	19.9 m
	2.6	5.2	6.2	7.3	19.6
	2.7	5.2	6.2	7.3	19.7
	2.8	5.2	6.2	7.3	19.7
	2.9	5.2	6.2	7.3	19.7
	3.0	5.2	6.2	7.3	19.8
90 degrees	2.5 m	5.2 m	5.8 m	7.9 m	19.5 m
	2.6	5.2	5.8	7.6	19.2
	2.7	5.2	5.8	7.3	18.9
	2.8	5.2	5.8	7.3	18.9
	2.9	5.2	5.8	7.3	18.9
	3.0	5.2	5.8	7.3	18.9

REGIONAL DISTRICT OF NANAIMO

BYLAW NO. 500

SCHEDULE '3B'

TABLE 3

DISABILITY SPACE DESIGNATION

Minimum Size

- | | | |
|---------------------|---|------------------------------------|
| Wall facing or sign | - | 0.3 m in width and 0.3 m in height |
| Pavement marking | - | 1.0 m in width |



**International Symbol of Accessibility
for the Handicapped**

REGIONAL DISTRICT OF NANAIMO

BYLAW NO. 500

SCHEDULE '3C'

CAMPGROUND REGULATIONS AND STANDARDS

REGIONAL DISTRICT OF NANAIMO

BYLAW NO. 500

SCHEDULE '3C'

CAMPGROUND REGULATIONS AND STANDARDS

Campgrounds shall be established or extended in accordance with the following regulations and standards:

1. LAYOUT STANDARDS

1.1 *Camping Spaces*

- 1) Every camping space shall have a minimum area of not less than 110 m².
- 2) Every camping space shall have a maximum slope of 5%.
- 3) No camping space shall be located within:
 - a) 3.0 m of an internal access road; and
 - b) the setback areas in the applicable zones established pursuant to Part 3.4 of this Bylaw.
- 4) Each camping space shall have one conveniently located parking space adjacent to the internal access road and may be sited in the area allotted for the 3.0 m setback.
- 5) No recreation vehicle or tent shall be located elsewhere in a campground than on a camping space.
- 6) Only one recreational vehicle or tent shall be located on a camping space.

1.2 *Buffer Area*

- 1) Within a setback area established pursuant to Part 3.4 of this Bylaw the following shall not be located:
 - a) recreational or service area, except for waterfront recreation or amenity areas;
 - b) a camping space or the residence of the owner or manager;
 - c) any building or structure, except a fence, a wall or a campground identification sign not exceeding 1.5 m² in area;
 - d) a sewage disposal system, other than such parts of such a system as may be underground;
 - e) vehicle parking; or
 - f) internal access roads except those that directly traverse the setback area to connect the internal access road system of the campground to a highway.

1.3 *Internal Access Roads*

- 1) All internal access roads in the campground shall be of hard durable surface so as not to produce dust.
- 2) The minimum internal access road width requirement shall be 6.0 m.

- 3) Dead-end internal access roads and cul-de-sacs shall have a turning circle radius of 12.0 m.
- 4) The maximum grade of any internal access road shall be 10%.

1.4 Parking

Every campground shall provide for:

- a) one parking space for each employee; and
- b) three parking spaces for the owner's or manager's residence.

2. SERVICING

2.1 Sewage Disposal

Sewage disposal shall be by a community sewer system or a septic disposal system constructed to the standards of the relevant enactments.

2.2 Washroom Facilities

Washroom facilities shall be provided in every campground, and:

- a) shall be located in a separate building or buildings;
- b) shall be located a maximum of 150 m from any camping space and a minimum of 4.5 m from any camping space;
- c) the quantity of toilets, urinals, wash basins and showers shall be provided in accordance with the following table:

**TABLE 1
WASHROOM FACILITIES**

No. of Camping Spaces	Toilets		Urinals	Washbasins		Showers	
1-15	1	1	1	1	1	1	1
16-30	1	2	1	2	2	1	1
31-45	2	2	1	3	3	1	1
46-60	2	3	2	3	3	2	2
61-80	3	4	2	4	4	2	2
81-100	3	4	2	4	4	3	3
101-130	4	5	3	5	5	4	4
131-150	5	6	3	5	5	5	5

2.3 Sewage Disposal Station

One sewage disposal station for use by recreational vehicles shall:

- a) be established in every campground that contains more than 60 camping spaces; and
- b) be located in an area apart from any internal access road and to allow easy and convenient access by recreational vehicles for the purpose of disposing of the contents of such vehicle's sewage storage tanks; and

- c) be constructed in accordance with Table '2A' and '2B' of this Schedule.

2.4 Water System

- 1) All camping spaces shall be a maximum of 60.0 m from a standpipe, constructed in accordance with Table '3A' of this Schedule.
- 2) Every campground that contains more than 60 camping spaces shall be serviced by a community water system or a water supply system built to the standards of the Regional District of Nanaimo, as specified in Schedule '4D' of this Bylaw, and:
 - a) a minimum of 0.18 m³ per day of potable water per camping space shall be provided;
 - b) 20% of all camping spaces in the campground shall be equipped with a water hook-up for recreational vehicles.

2.5 Laundry Facilities

Laundry facilities shall be:

- a) provided in every campground that contains more than 60 camping spaces;
- b) provided in the ratio of 1 clothes washing machine and 1 clothes dryer for every 30 camping spaces or portion thereof;
- c) located in a separate room of a sanitary facility or building or in a separate building.

2.6 Garbage Disposal

- 1) For the disposal of garbage a minimum of one container shall be provided for every 2 camping spaces.
- 2) Each container shall be durable, insect-tight, water-tight and rodent-proof and shall be constructed in general compliance with standards set out in Tables '4A' or '4B' of this Schedule.

REGIONAL DISTRICT OF NANAIMO

BYLAW NO. 500

SCHEDULE '3C'

TABLE 2A

TRAILER SEWAGE DISPOSAL SYSTEM

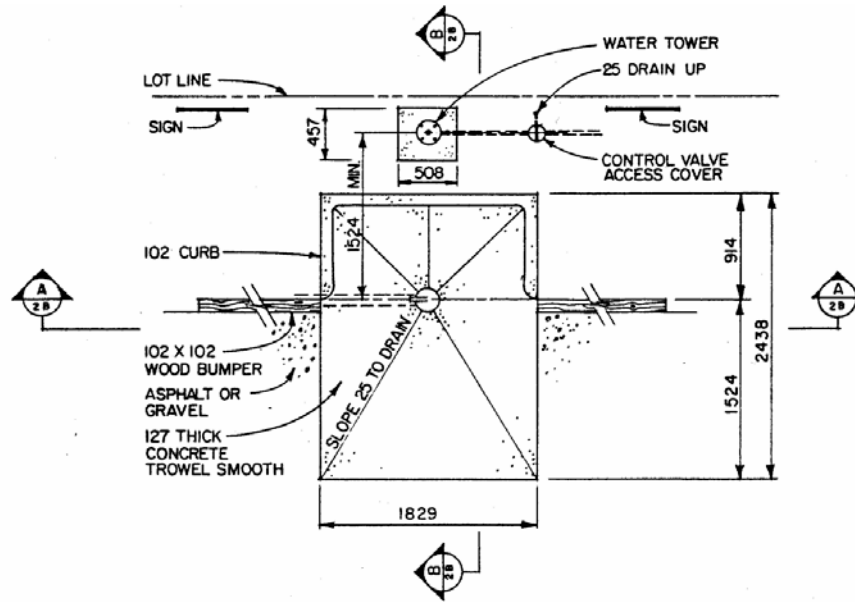

PLAN
(All Dimensions in Millimetres)

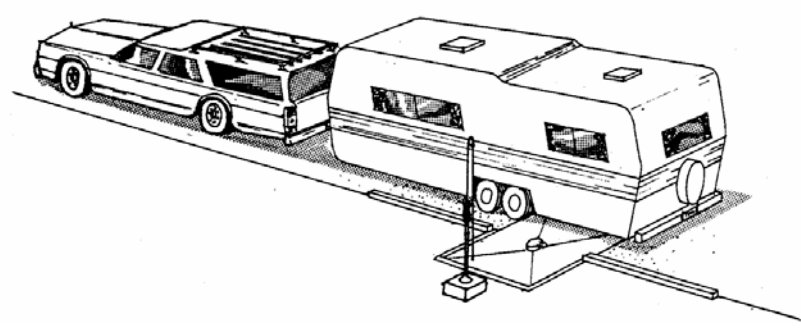

REGIONAL DISTRICT OF NANAIMO

BYLAW NO. 500

SCHEDULE '3C'

TABLE 2B

TRAILER SEWAGE DISPOSAL SYSTEM

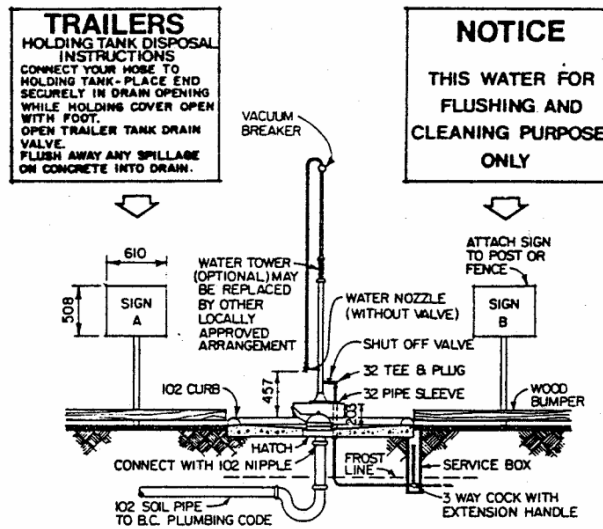

CROSS-SECTION A-A
(All Dimensions in Millimetres)

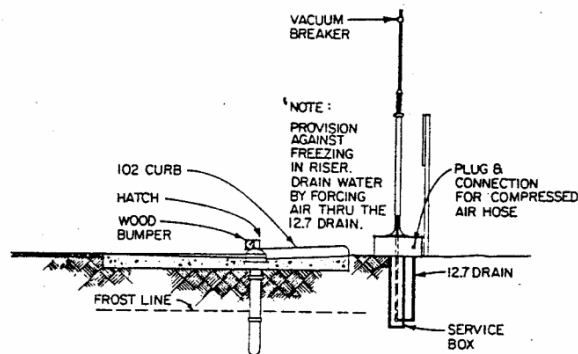

CROSS-SECTION B-B
(All Dimensions in Millimetres)

REGIONAL DISTRICT OF NANAIMO

BYLAW NO. 500

SCHEDULE '3C'

TABLE 3A

WATER STANDPIPE TAP

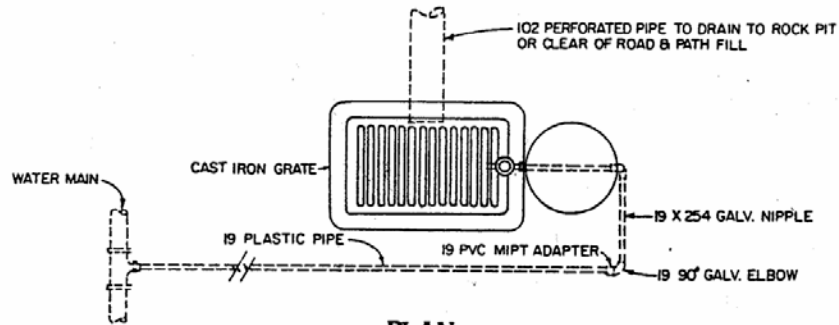

PLAN
(All Dimensions in Millimeters)

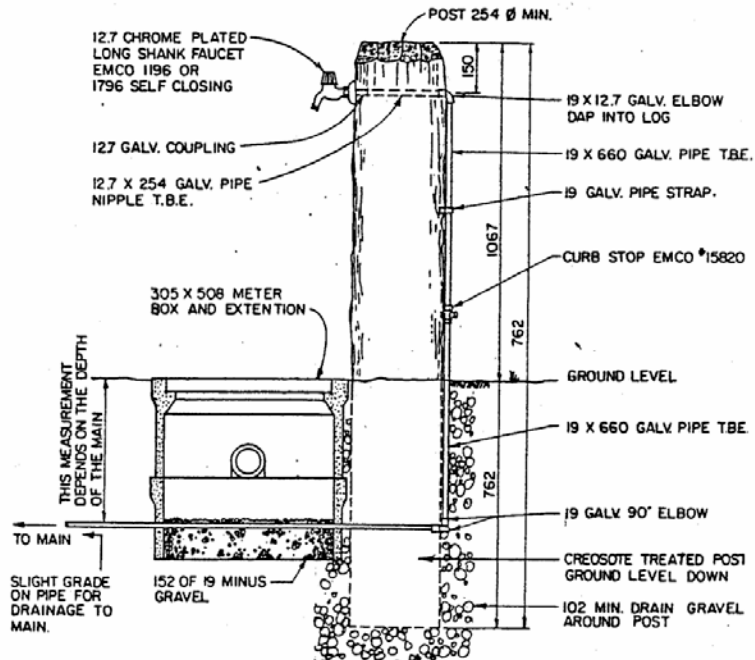

ELEVATION
(All Dimensions in Millimetres)

REGIONAL DISTRICT OF NANAIMO

BYLAW NO. 500

SCHEDULE '3C'

TABLE 4A

GARBAGE CAN HOLDER

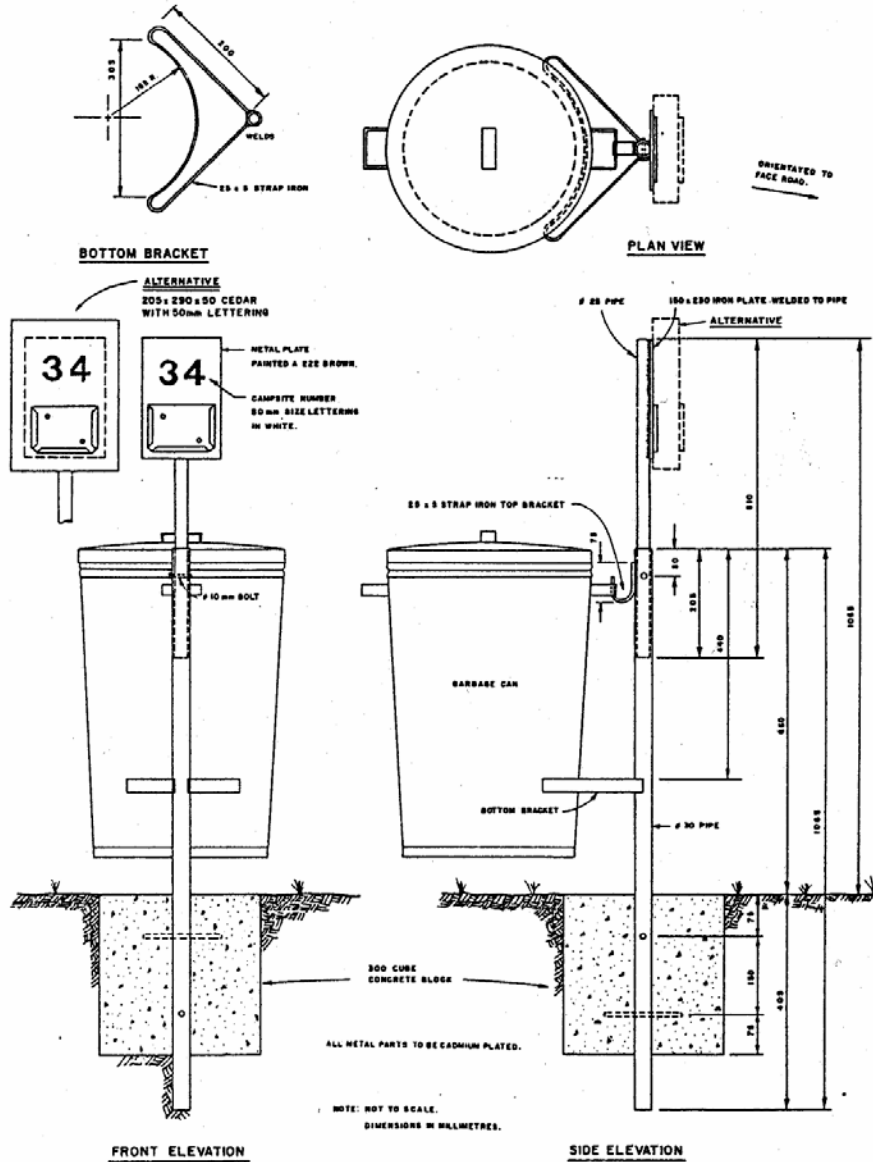

REGIONAL DISTRICT OF NANAIMO

BYLAW NO. 500

SCHEDULE '3C'

TABLE 4B

SUSPENDED GARBAGE CONTAINER

(170 l Oil Barrel)

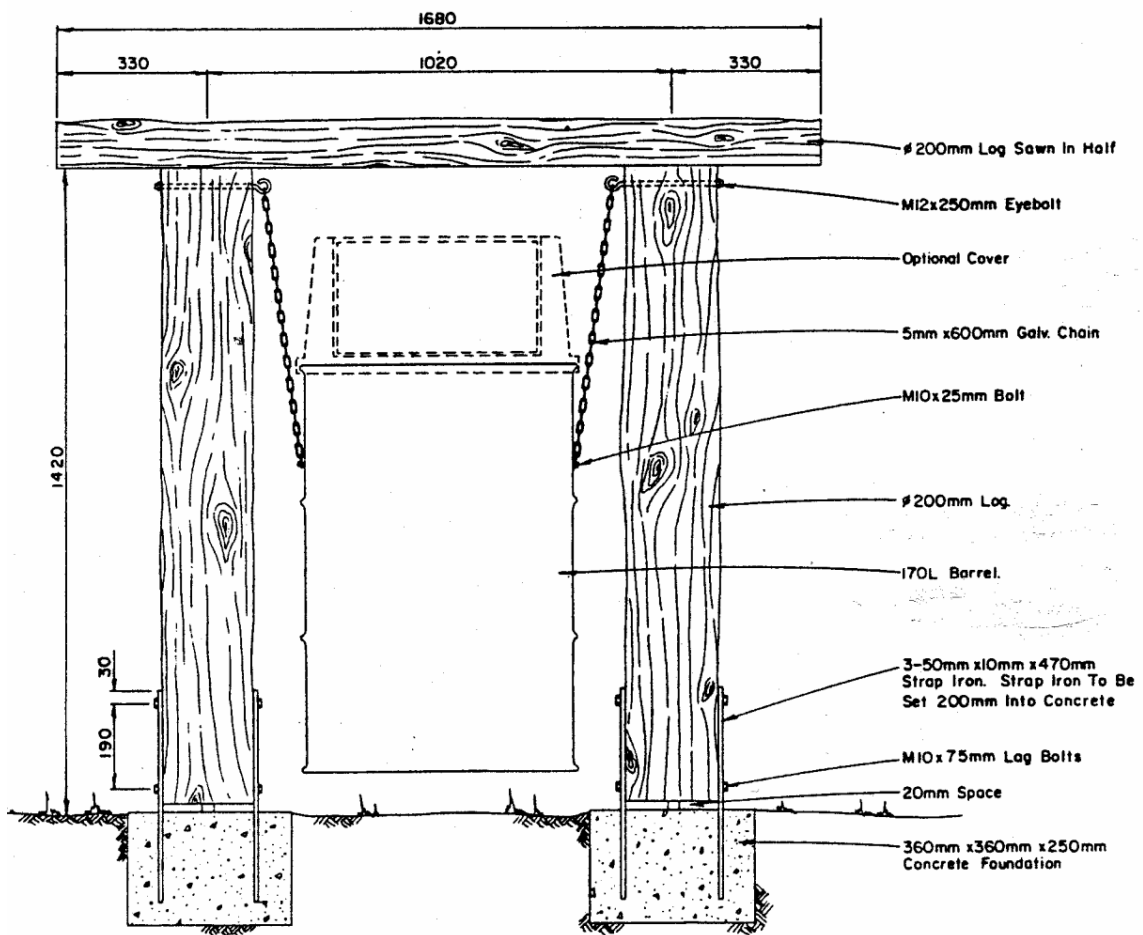

ELEVATION

REGIONAL DISTRICT OF NANAIMO

BYLAW NO. 500

SCHEDULE '3D'

**RESIDENTIAL MOBILE HOME PARK
REGULATIONS AND STANDARDS**

REGIONAL DISTRICT OF NANAIMO

BYLAW NO. 500

SCHEDULE '3D'

RESIDENTIAL MOBILE HOME PARK REGULATIONS AND STANDARDS

Mobile home parks shall be established or extended in accordance with the following regulations and standards:

1. GENERAL REQUIREMENTS

- 1) No person shall establish, construct, alter or subdivide a mobile home park until written approval of detailed plans or specifications is received and a Mobile Home Park Permit is issued by the Regional District.
- 2) Nothing contained in this Schedule shall relieve any person from obtaining the necessary building permits and approvals for buildings and structures constructed, located or relocated in a mobile home park.
- 3) A copy of the Mobile Home Park Permit, a copy of this Schedule, and Part 3.4.66 of this Bylaw shall be permanently posted in the mobile home park office for the reference of mobile home park occupiers.

2. MOBILE HOME PARK APPLICATION, FEE, APPROVAL AND PERMIT

2.1 Application

All applications for approval of plans and specifications shall be made in writing to the Regional District and shall include 2 full sets of working drawings to scale showing:

- a) the name and address of the applicant;
- b) the legal description of the land on which the proposed mobile home park is to be established, constructed, altered or extended;
- c) a north arrow and notations of scales used;
- d) the parcel dimensions;
- e) the location and dimensions of the setback area;
- f) the number, location, dimensions and designation of all mobile home spaces;
- g) the location, dimensions and grade of all internal access roads and their relationship to existing highways;
- h) the location and dimensions of all recreation or common areas;
- i) the location and dimensions of the owner's or manager's dwelling unit and all other accessory buildings;
- j) the location and details of the source of potable water supply, treatment plants, distribution lines and outlets;
- k) the location and details of all connections to the sewer, sewer lines, septic tank and subsurface disposal fields;
- l) the location and details of all on-site refuse disposal areas;
- m) a landscaping plan for the mobile home park;
- n) all watercourses or water frontage within or adjacent to the mobile home park;
- o) all steep banks or slopes within or adjacent to the land concerned; and
- p) any other information the Regional District may deem necessary.

2.2 Permit Application Fee

Each application for a Mobile Home Park Permit shall be accompanied by an application fee of \$25.00 for the first mobile home space and \$10.00 for each additional mobile home space shown on the mobile home park plan.

2.3 Approval of Application and Permit

- 1) No person shall establish, construct or alter a mobile home park without a Mobile Home Park Permit issued by the Regional District.
- 2) A Mobile Home Park Permit shall permit the establishment of a mobile home park on the land concerned only in compliance with the mobile home park plan as approved and for which a permit has been issued.
- 3) A Mobile Home Park Permit shall not be issued until the necessary permits and approvals have been granted by the other authorities also having jurisdiction.
- 4) Subsequent to examination of an application the Regional District shall notify the applicant in writing within 60 days that either a Mobile Home park Permit is issued or that it is refused and the reasons therefore.
- 5) In the event that after the issuance of a Mobile Home Park Permit, the construction authorized thereunder is not commenced within 180 days from the date of issuance, then such permit shall be void, and the work shall not be commenced until a new permit has been issued and the fee paid.

3. STANDARDS

3.1 Mobile Home Spaces

- 1) Every mobile home space shall:
 - a) have a minimum area of 370 m²;
 - b) have a maximum of 6% longitudinal and 15% cross or crown gradient;
 - c) have 1 conveniently located parking space in the mobile home space area, and such parking space shall have a minimum width of 3.0 m and a minimum length of 6.0 m;
 - d) be properly drained;
 - e) be clearly numbered; and
 - f) have a clearly discernible mobile home pad.
- 2) No mobile home shall be located elsewhere in a mobile home park than on a mobile home space, and not more than 1 mobile home shall be located on a mobile home space.

3.2 Mobile Home Standards

- 1) Every mobile home located on a mobile home space shall be supported by a double blocking system of blocking in which blocks of alternate courses are placed at 90 degrees.
- 2) In a mobile home:
 - a) the installation of all woodstoves and chimneys;
 - b) the installation and maintenance of all oil burners and oil-burning equipment and appliances using inflammable liquids as fuel;
 - c) the storage and disposal of inflammable liquids and oils;
 - d) the installation, maintenance, carriage and use of compressed gas systems;
 - e) the plumbing and electrical installation; and
 - f) the connections to services; shall be in accordance with the regulations of the authority having jurisdiction.

- 3) Skirtings shall be installed within 60 days of installation of a mobile home on a mobile home pad.

3.3 Accessory Building and Structures

- 1) One storage shed or utility building may be constructed on each mobile home space provided that the building has:
 - a) a maximum height of 2.5 m;
 - b) a maximum floor area of 9.0 m².
- 2) Common accessory buildings and structures shall be limited to buildings and structures generally intended for the common use of mobile home park occupiers and includes facilities for storage, laundry, service and recreation.

3.4 Owner's or Manager's Dwelling Unit

The space allotted for the owner's or manager's dwelling unit shall be developed in the same manner as a mobile home space where applicable, except where the residence is not a mobile home, then the minimum space allotted shall be 500 m².

3.5 Siting

No part of any mobile home or any addition shall be located within:

- a) 6.0 m of another mobile home or addition thereto;
- b) 2.0 m of an internal access road or common parking area;
- c) 1.5 m of rear and side mobile home space lines;
- d) 6.5 m of any common accessory building.

3.6 Access

- 1) No mobile home park shall be established or extended unless the highway access to the mobile home park is approved by the authority having jurisdiction.
- 2) A second access from a highway separated by at least 60.0 m from the first access shall be provided for each mobile home park containing 50 or more mobile home spaces.
- 3) Access to all parts of a mobile home park shall be by way of the internal access roads and no part of a mobile home park shall have direct access from a highway.

3.7 Layout

The minimum frontage of each mobile home space on the internal access road shall be 12.0 m, except in the case of a mobile home space abutting a cul-de-sac the minimum frontage shall be 6.0 m.

3.8 Internal Access Roads

- 1) All internal access roads within a mobile home park shall be:
 - a) of a hard durable surface so as not to produce dust;
 - b) well drained;
 - c) maintained;
 - d) adapted to the topography.
- 2) The maximum grade of all internal access roads shall be 7%.
- 3) The minimum internal access road width requirements shall be as follows:
 - a) access roads from a mobile home park to a highway shall have a minimum surfaced width of 6.5 m and a right of way width of 15.0 m, and no parking shall be allowed on such internal access roads.

- b) all other internal access roads:
 - i) with parking on both sides shall have a minimum surfaced width of 11.0 m and a right of way of 14.0 m;
 - ii) with parking on one side shall have a minimum surfaced width of 8.5 m and a right of way of 12.0 m;
 - iii) with no parking shall have a minimum surfaced width of 5.0 m and a right of way of 12.0 m.
- 4) Cul-de-sacs shall not exceed 100 m in length.
- 5) Dead-end internal access roads and cul-de-sacs shall have a turning circle right of way at the dead end with a radius of at least 12.0 m.

3.9 Parking

For every 2 mobile home spaces, 1 additional parking space shall be provided, and shall:

- a) be located in the internal access road or in grouped parking areas of no larger than 20 parking spaces;
- b) have a minimum width of 3.0 m and a minimum length of 6.0 m;
- c) be provided and maintained with a hard durable surface that does not produce dust;
- d) be property drained.

3.10 Buffer Area

- 1) To provide a buffer area, no mobile home space shall be located within the setback areas provided in Part 3.4 of this Bylaw.
- 2) Within a setback required pursuant to Part 3.4 of this Bylaw the following shall not be located:
 - a) recreational or service areas, except for waterfront recreation or amenity areas;
 - b) mobile home spaces or the owner's or manager's residence;
 - c) any building or structure, except a fence, a wall or mobile home park identification sign not exceeding 1.5 m² in area;
 - d) a sewage disposal system;
 - e) vehicle parking;
 - f) internal access roads, except those that directly connect the road system of the mobile home park to a highway.

3.11 Recreation Area

- 1) Not less than 5% of the gross site area of the mobile home park shall be devoted to tenant's recreational uses, and shall be provided in a convenient and accessible location; and for the purpose of calculating recreational space requirements, any indoor recreational space provided shall be counted as double its actual floor area.
- 2) The recreation areas shall not include setback areas, parking areas, common accessory buildings, internal access roads and mobile home spaces.
- 3) In mobile home parks where more than 1000 m² of recreation space is required, 2 or more recreation areas may be provided.
- 4) Recreation areas in the mobile home park, except indoor recreation facilities, shall be of grass or asphaltic surface and shall be property landscaped.

3.12 Refuse Disposal

- 1) No person residing in a mobile home park shall dispose of refuse or any sort of waste except in accordance with the arrangements made by the owner or manager of the mobile home park, and approved by the authority having jurisdiction.

- 2) The owner or manager of a mobile home park may establish 1 or more containers within the park for the collection of refuse. Such containers shall be durable, insect-tight, water-tight and rodent-proof.

3.13 Water System

- 1) Pursuant to Part 3.4 of this Bylaw, in the event that the number of mobile homes per mobile home park does not require the provision of a community water system, then every mobile home park shall have a water supply system built to the standards of the Regional District of Nanaimo, as specified in Schedule '4C' of this Bylaw.
- 2) The water supply system shall furnish a constant supply of potable water that is under a minimum working pressure of 200 kPa and not over a maximum working pressure of 350 kPa at all outlets.
- 3) The water supply system shall distribute water to each:
 - a) accessory building, if required;
 - b) mobile home space by a distribution branch line with a minimum diameter of 18 mm;
 - c) hydrant;
 - d) hose bib.

3.14 Sewage Disposal

Pursuant to Part 3.4 of this Bylaw, in the event that the number of mobile homes per mobile home park does not require the provision of a community sewer system, then every mobile home park shall be served by a septic disposal system constructed to the standards of the authority having jurisdiction.

3.15 Fire Hydrants

Fire hydrants meeting the requirements of the Regional District as specified in Schedule '4C' of this Bylaw shall be installed and connected to the internal water supply of a mobile home park so that no mobile home space is beyond 120 m from a fire hydrant, as measured along the internal access road.

3.16 Streetlighting

Streetlighting shall be installed and maintained to adequately illuminate the traveled portion of the internal access roads at the following locations:

- a) the intersection of internal access roads and a highway;
- b) all internal intersections;
- c) the turning circle of cul-de-sacs;
- d) any point at which an internal access road changes direction 30 degrees or more.

REGIONAL DISTRICT OF NANAIMO

BYLAW NO. 500

SCHEDULE '3E'

SETBACKS FROM WATERCOURSES

REGIONAL DISTRICT OF NANAIMO

BYLAW NO. 500

SCHEDULE '3E'

TABLE 1

SETBACKS FROM WATERCOURSES

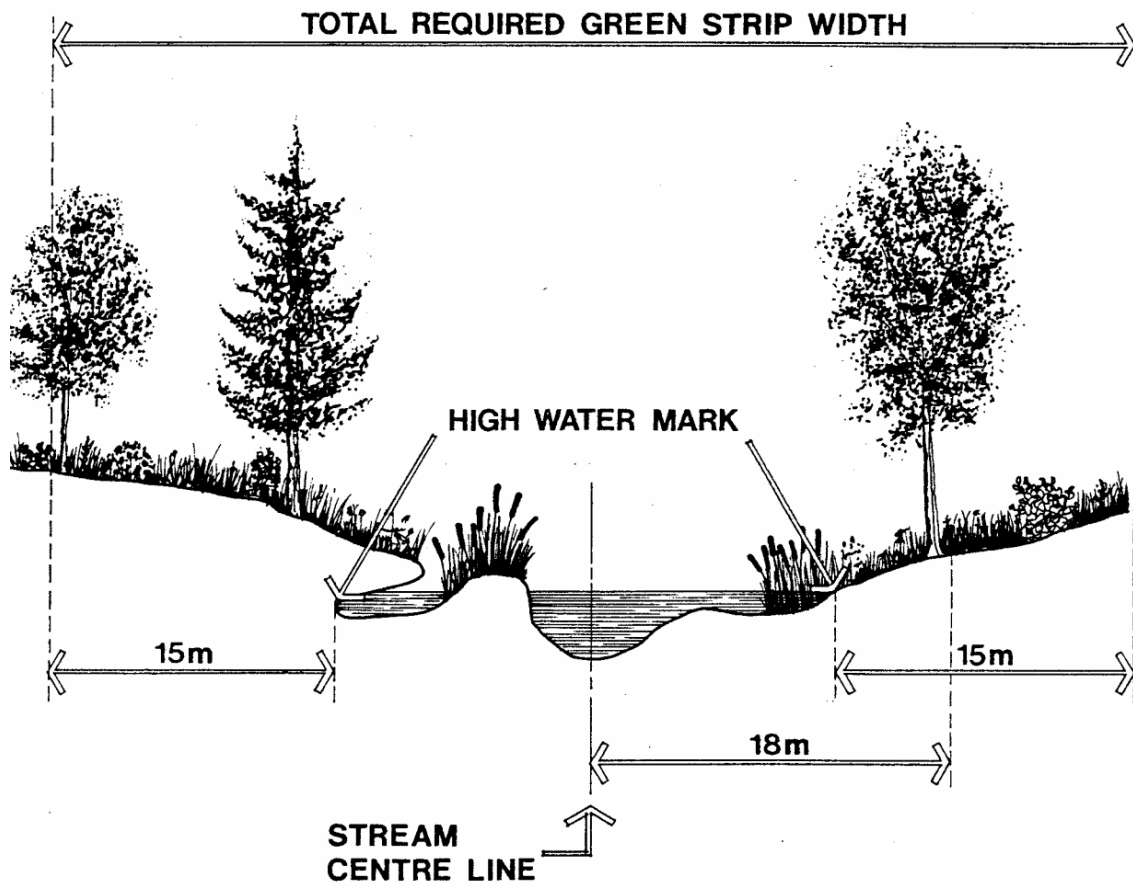

REGIONAL DISTRICT OF NANAIMO

BYLAW NO. 500

SCHEDULE '3E'

TABLE 2

SETBACKS FROM WATERCOURSES

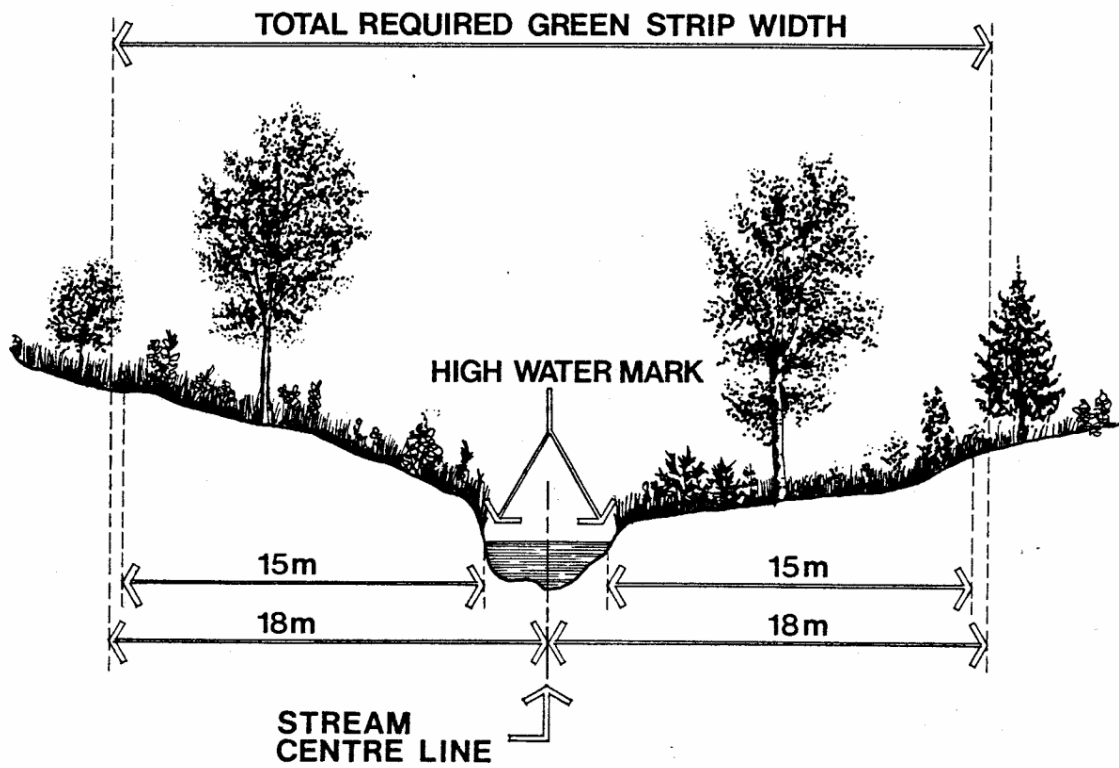

REGIONAL DISTRICT OF NANAIMO

BYLAW NO. 500

SCHEDULE '3E'

TABLE 3

SETBACKS FROM WATERCOURSES

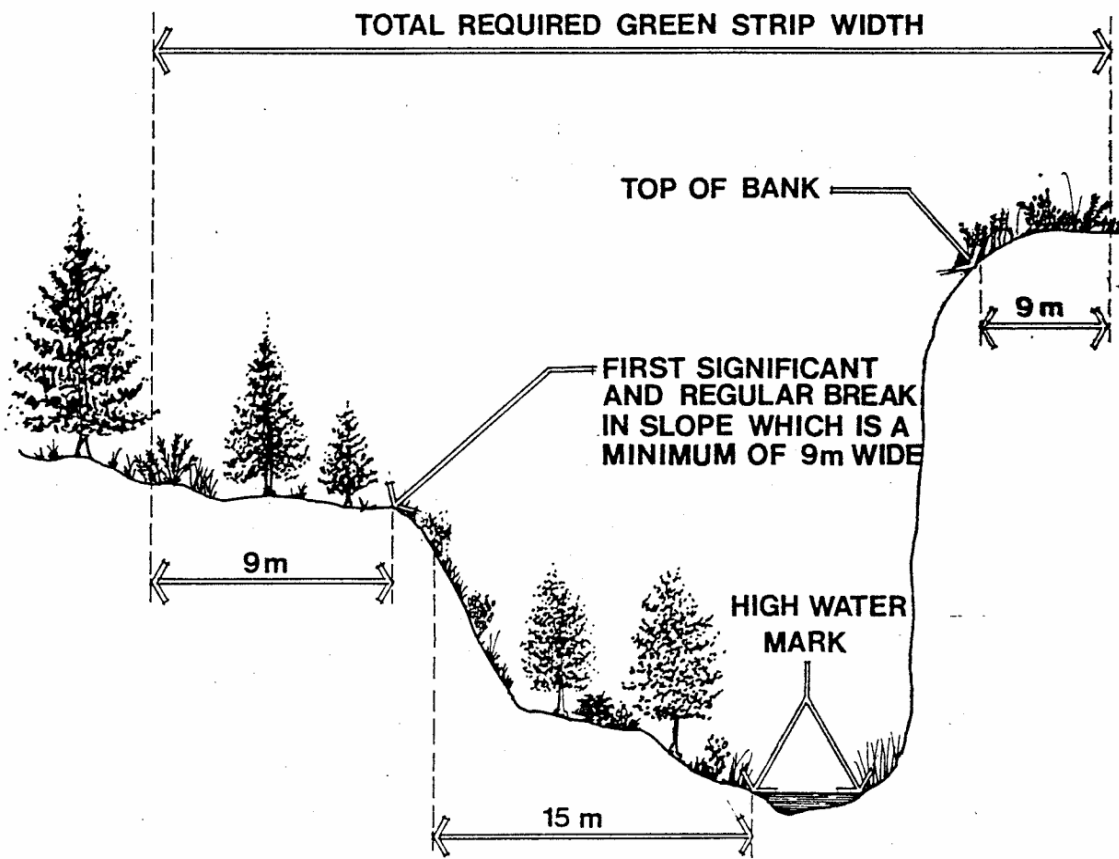

REGIONAL DISTRICT OF NANAIMO

BYLAW NO. 500

SCHEDULE '3F'

LANDSCAPING REGULATIONS AND STANDARDS

REGIONAL DISTRICT OF NANAIMO

BYLAW NO. 500

SCHEDULE '3F'

LANDSCAPING REGULATIONS AND STANDARDS

TABLE OF CONTENTS

PART 1 - INTERPRETATION.....	3F-3
1.1 Definitions	3F-3
PART 2 - GENERAL.....	3F-4
2.1 Requirement.....	3F-4
2.2 Procedure	3F-5
2.3 Drawings and Specifications.....	3F-5
2.4 Variations from Standards.....	3F-5
2.5 Applicability ⁵	3F-5
PART 3 - DESIGN.....	3F-5
3.1 Design Standards - Landscape Screen	3F-6
3.2 Design Standards - Landscape Buffer	3F-6
3.3 Selection of Introduced Vegetation	3F-6
3.4 Planted Berms	3F-6
PART 4 - CONSTRUCTION.....	3F-7
4.1 Timing	3F-7
4.2 General	3F-7
PART 5 - SECURITY DEPOSIT.....	3F-7
5.1 Requirement.....	3F-7
5.2 Type and Value of Security Deposit.....	3F-7
5.3 Release of Security Deposit.....	3F-8

⁵ Bylaw No. 500.360, adopted January 25, 2011

REGIONAL DISTRICT OF NANAIMO

BYLAW NO. 500

SCHEDULE '3F'

LANDSCAPING REGULATIONS AND STANDARDS

PART 1 - INTERPRETATION

1.1 Definitions

In this Schedule unless the context otherwise requires:

designated highway means a road listed in Appendix 1 of this Schedule;

fence means a barrier under 2.0 m in height assembled of wooden planks or panels, rock, concrete or brick or any combination thereof;

introduced vegetation means vegetation planted on a parcel to provide a landscape buffer and includes ground covers, vines, shrubs and trees, but specifically excludes weed species;

landscape buffer means an area of preserved natural vegetation, introduced vegetation or a planted berm or any combination thereof;

landscape plan means drawings and specifications, as required by this Schedule, showing proposed landscape buffer or landscape screen;

landscape screen means an area of trees, fences, evergreen vegetation or planted berm or any combination thereof, intended to block or mask from view certain uses as specified in this Schedule;

landscaping means the design, construction and maintenance of a landscape buffer, landscape screen, fencing, land contouring or drainage works;

natural vegetation means vegetation existing on site prior to clearing or cutting and includes vegetation native to Southwestern British Columbia, but specifically excludes weed species;

planted berm means a mound of earth the surface of which is covered by introduced vegetation.

site improvements means the design, construction or maintenance of physical alterations or improvements to land intended to address the safety and functionality of development, including, but not limited to, parking, access or removal of existing structures or buildings.

PART 2 - GENERAL

2.1 Requirement

- 1) A landscape buffer shall be provided within the setback area of a parcel adjacent to a designated highway to provide vegetative landscape separation between industrial, commercial and multiple dwelling unit development uses of the parcel from a designated highway.
- 2) A landscape screen shall be provided within the setback area of a parcel adjacent to a designated highway to mask outdoor storage and outdoor industrial activity of a parcel where storage or industrial activity is taking place in conjunction with an industrial, commercial or multiple dwelling unit use of the parcel.
- 3) Where an owner proposes to use a parcel of land in circumstances or in a manner that requires a landscape buffer or landscape screen pursuant to Section 2.1.1 or Section 2.1.2 of this bylaw, the owner shall submit a landscape plan to the Regional District at the time of:
 - a) application for a building permit;
 - b) actual commencement of the use;
 - c) application for a development permit;
 - d) with respect to those parts of the Regional District not subject to the provisions of "Regional District of Nanaimo Building Regulations and Fees Bylaw No. 800, 1989" at the time of an application to rezone the property.
- 4) All landscaping shall be permanently maintained in good condition with the same quality and quantity of landscaping as was initially approved and without alteration of the approved design; the owner shall make provision for permanent irrigation works necessary to water the landscaping.
- 5) The design of landscaping shall be such that the growth of roots, trunks and branches of natural or introduced vegetation or the location of planted berms shall not conflict with utilities, structures, necessary access or a required sight triangle.

2.2 Procedure

In satisfying the requirements of this Schedule, the applicant shall complete three steps as follows:

1) Landscape Plan

Drawings and specifications of the proposed landscaping, which shall include a schedule of construction and date of completion, shall be submitted in duplicate to the Regional District for approval before any landscape works or building construction are started.

2) Landscape Works

The applicant shall complete the proposed work in accordance with the plans and specifications approved by the Regional District.

The Regional District will inspect the landscaping from time to time for conformity to these standards. There will be no charge for such inspections. The applicant shall be responsible for construction layouts, detailed field supervision of the work and as-constructed drawings.

3) Completion and Acceptance

Once the work is completed two sets of as-constructed drawings shall be submitted to the Regional District.

Completion of the landscaping in accordance with the approved landscape plan is required prior to final building inspection for works under a building permit where a landscape plan was required.

2.3 Drawings and Specifications

Drawings and specifications required for the review of proposed landscaping shall:

- a) be in duplicate, accurately dimensioned and at a suitable scale;
- b) show the location and dimensions of the parcel on which the landscaping is to occur;
- c) show the location and extent of proposed and existing buildings, structures, services, utilities and circulation, including paved and concrete surfaces;
- d) show the existing and proposed grades at a contour interval of 0.200 m and such grades shall be relevant to existing roadways and/or structures;
- e) show the location, size and species of all natural vegetation clearly indicating vegetation that shall remain and vegetation that shall be removed;
- f) show the location, size, quantity and species of all introduced vegetation;
- g) show the location, extent and materials of any proposed fencing;
- h) include sectional details including cross sections of the landscaping taken at sufficient locations to adequately illustrate the effect of landscaping, planting details, finishes and the location at which sectional details are taken is to be noted on a plan;
- i) include such other information as is necessary to illustrate all essential features and methods of planting and construction;
- j) include an outline of the proposed maintenance schedule.

2.4 Variations from Standards

Where the applicant wishes to vary from these standards, the applicant may submit a development variance permit application or development permit application.

2.5 Applicability⁶

Notwithstanding any other regulation in this Bylaw, the landscaping regulations and standards prescribed herein shall not apply to Electoral Area 'G' of the Regional District of Nanaimo

PART 3 - DESIGN

3.1 Design Standards - Landscape Screen

The following requirements shall be met in providing a landscape screen where required by this Bylaw:

- 1) A landscape screen shall provide at least seventy-five percent screening from grade level to a height of 2.0 m and at least twenty-five percent screening from the height of 2.0 m above grade to 5.0 m above grade, as illustrated in Table 1 of this Schedule.
- 2) The landscape screen shall include planting or retaining one evergreen tree for every 4 m of parcel frontage on a designated highway; such trees shall have a minimum height of 2.0 m and may be grouped or clustered.

⁶ Bylaw No. 500.360, adopted January 25, 2011

3.2 Design Standards - Landscape Buffer

The following requirements shall be met in providing a landscape buffer where required by this Bylaw:

- 1) A landscape buffer shall be a minimum of 5.0 m in width.
- 2) A minimum of 25% of the vegetation shall be evergreen shrubs with a minimum height of 0.5 m, and introduced shrubs shall be a minimum No. 5 pot (5 gallon) nursery standard at the time of planting.
- 3) The landscaping buffer shall include a minimum of one tree for every 10 m of parcel frontage, and such trees shall have a minimum height of 2.0 m and may be grouped or clustered.
- 4) A permanent curb of a minimum 15 cm in height shall be provided to protect landscaping from potential vehicular damage.
- 5) The use of a fence is to be accessory to the use of introduced vegetation, existing vegetation, a planted berm or any combination thereof in satisfying the requirements of a landscape buffer or landscape screen. Advertising display shall not be permitted on fences.

Fences shall be structurally sound and shall be designed and built to withstand wind and snow loads.

3.3 Selection of Introduced Vegetation

- 1) In the selection of introduced vegetation, species shall be selected which satisfy the requirements of screening and are adapted to the site specific conditions of the soil, climate and topography on which such vegetation is to be planted.
- 2) Individual plants to be used in landscaping shall have normal, well developed branches and vigorous fibrous root systems; such plants shall be healthy, vigorous and free from defects, decay, disfiguring roots, sunscald, injuries, abrasions of the bark, plant diseases, insect pests' eggs, borers and all forms of infestation or objectionable disfigurements.

3.4 Planted Berms

The sides of slopes of planted berms within proposed landscaped areas are to be within the following ranges:

Type of Planting	Minimum Slope	Maximum Slope
planted areas with greater than 70% ground cover	1:50	1:2
lawn and grass	1:50	1:3
planted areas with less than 70% ground cover	1:50	1:4

PART 4 - CONSTRUCTION

4.1 Timing

The coordination and scheduling of all work on the site shall be such that no damage occurs to introduced vegetation before or after installation or to natural vegetation to be retained or to existing soil conditions as determined by local weather conditions and the requirements of living plant material.

4.2 General

Imported topsoil shall be free from subsoil, roots, toxic materials, stones over 30 mm in diameter and foreign objects. Topsoil shall be free from crabgrass, couchgrass, equisetum or noxious weeds or seeds or parts thereof.

The working area shall be maintained in an orderly manner and shall not be encumbered with equipment, materials, or debris.

Clean up shall be a continuing process from the start of the work to final acceptance of the project. Property on which work is in progress shall at all times be kept free from accumulations of waste materials or rubbish. Accumulations of waste materials which might constitute a fire hazard shall not be permitted. Spillage from hauling vehicles on traveled public or private roads shall be promptly cleaned up. On completion of construction, all temporary structures, rubbish and waste materials resulting from the operations, shall be removed.

PART 5 - SECURITY DEPOSIT

5.1 Requirement

A security deposit shall be submitted to the Regional District for development permits which include landscaping and/or site improvement provisions.

The security deposit shall be submitted with the application prior to proceeding to the Electoral Area Planning Committee. A detailed planting plan as specified in Section 2.2 shall also be submitted at this time.

5.2 Type and Value of Security Deposit

The security deposit shall be in the form of either a standby irrevocable letter of credit, cash, or a certified cheque, or other acceptable equivalent, and shall be submitted in a form satisfactory to the Regional District.

The value of the security deposit shall be equal to the estimated total cost (i.e., materials and installation) of all of the required landscaping and/or site improvements. The total cost of these works shall be estimated as follows:

- a) \$50.00 per square metre of landscaping as indicated on submitted plans; and
- b) The cost of site improvements shall be determined by an itemized cost estimate of materials and installation. The cost estimate is to be completed by a professional landscape architect, a nursery person or landscape contractor or an equivalent agreed upon by the Regional District, and is to be submitted at the time of application. The developer assumes sole responsibility for undertaking and financing the cost estimate.

5.3 Release of Security Deposit

The security shall be released following the completion of all approved landscaping and/or site improvement works as specified in the development permit to the satisfaction of the Regional

District. A one-year written guarantee from a landscape contractor is also required, otherwise 25% of the landscaping cost will be retained to ensure proper maintenance for one year period.

In the event that the landscaping and/or site improvements are at variance with approved works and/or not completed to an acceptable standard and/or not completed within a specified time period, the Regional District may use the security deposit for the purpose of entering upon the subject property and completing the approved works and/or for pursuing any necessary legal or court judgment as required.

In the event that additional time is required to complete the landscaping and/or site improvements due to unforeseen circumstances, a written request shall be made to the Planning Department indicating the reason for an extension and the expected date of completion.

When a security deposit is in the form of a standby irrevocable letter of credit, it shall include provisions for its extension and/or renewal in the event that works cannot be completed before its expiry date. A minimum of 45 days notice of the need for an extension is required. Alternatively, and upon approval by the Regional District, a new standby irrevocable letter of credit with a revised expiry date shall be provided to the Regional District in these situations.

REGIONAL DISTRICT OF NANAIMO

BYLAW NO. 500

SCHEDULE '3F'

TABLE 1

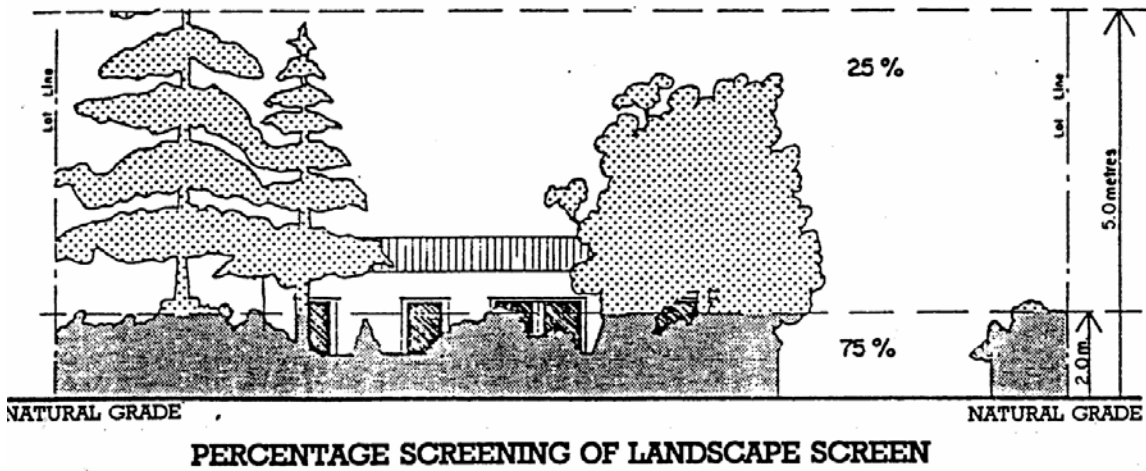
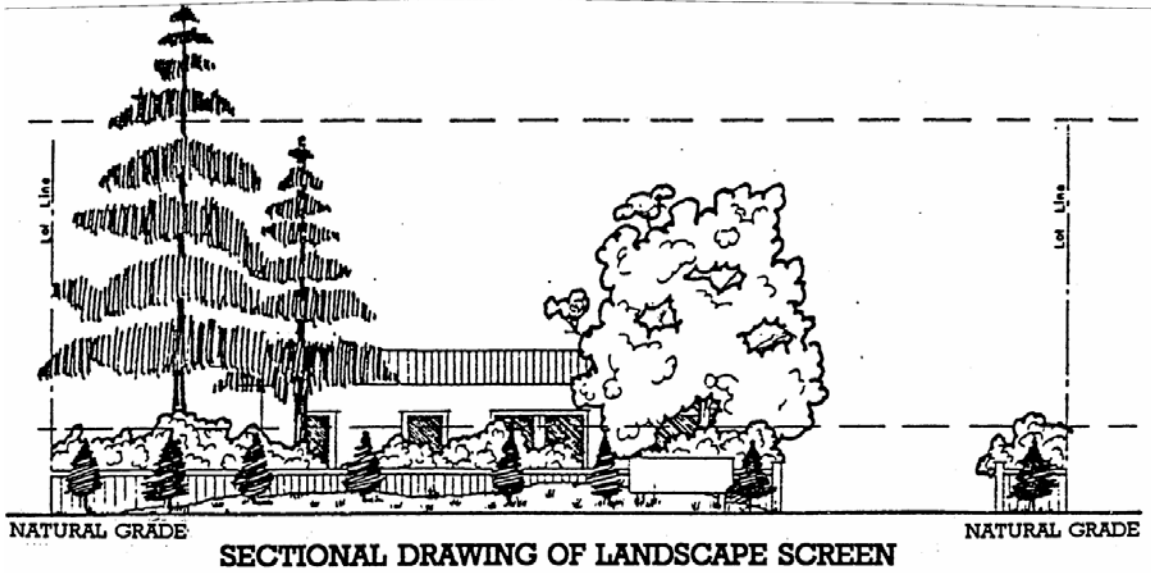

LANDSCAPING REGULATIONS

SCHEDULE '3F'

APPENDIX 1

ALPHABETICAL LIST OF DESIGNATED HIGHWAYS

Bennett Road, French Creek
Cedar Road, Cedar
Church Road, French Creek
Dolphin Drive, Nanoose
Eaglecrest Drive, French Creek
Fairwinds Drive, Nanoose
Industrial Road, Lantzville
Island Highway and service roads
Lantzville Road, Lantzville
Lee Road, French Creek
Lowrys Road, French Creek
Morningstar Drive, French Creek
MacMillan Road, Cedar
Northwest Bay Road, Nanoose and Parksville East
Parksville By Pass, Parksville East
Powder Point Road, Nanoose
School House Road, South Wellington
Trans Canada Highway, Cedar, Cranberry, Bright Area and
service roads
Wembley Road, French Creek
Yambury Road, French Creek